

DE Gebrauchsanleitung / Montageanleitung

FR Mode d'emploi / Instructions de montage

■ Instructions for use / assembly instructions

2

3

4

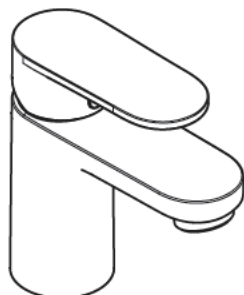

Vernis Blend 70

71550XXX / 71557000 / 71558XXX /
71570000 / 71587000

Vernis Blend 70 CoolStart

71584XXX

Vernis Blend 100

71551XXX / 71559000 / 71571000 /
71580XXX / 71588000

Vernis Blend 100 CoolStart

71585XXX

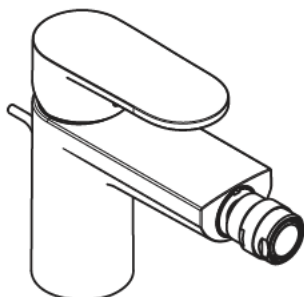

Vernis Blend

71210XXX



Sicherheitshinweise

- ⚠ Bei der Montage müssen zur Vermeidung von Quetsch- und Schnittverletzungen Handschuhe getragen werden.
- ⚠ Das Produkt darf nur zu Bade-, Hygiene- und Körperreinigungszwecken eingesetzt werden.
- ⚠ Große Druckunterschiede zwischen den Kalt- und Warmwasseranschlüssen müssen ausgeglichen werden.

Montagehinweise

- Vor der Montage muss das Produkt auf Transportschäden untersucht werden. Nach dem Einbau werden keine Transport- oder Oberflächenschäden anerkannt.
- Die Leitungen und die Armatur müssen nach den gültigen Normen montiert, gespült und geprüft werden.
- Die in den Ländern jeweils gültigen Installationsrichtlinien sind einzuhalten.
- Das Ablaufventil darf nur zum bestimmungsgemäßen Gebrauch verwendet werden. Das Befestigen von anderen Gegenständen z. B. einer Halbsäule an dem Ablaufventil ist nicht zulässig.
- Bei Problemen mit dem Durchlauferhitzer oder wenn mehr Wasserdurchsatz gewünscht wird, kann der EcoSmart® (Durchflussbegrenzer), der hinter dem Luftsprudler sitzt, entfernt werden.

Technische Daten

Armatur serienmäßig mit EcoSmart® (Durchflussbegrenzer)

Betriebsdruck:	max. 1 MPa
Empfohlener Betriebsdruck:	0,1 - 0,5 MPa
Prüfdruck:	1,6 MPa
	(1 MPa = 10 bar = 147 PSI)
Heißwassertemperatur:	max. 60 °C
Thermische Desinfektion:	70 °C / 4 min

Das Produkt ist ausschließlich für Trinkwasser konzipiert!

Symbolerklärung



Kein essigsäurehaltiges Silikon verwenden!



Justierung (siehe Seite 35)

Einstellen der Warmwasserbegrenzung. In Verbindung mit Durchlauferhitzern ist eine Warmwassersperre nicht zu empfehlen.



Maße (siehe Seite 40)



Durchflussdiagramm

(siehe Seite 42)

- ① mit EcoSmart®
- ② ohne EcoSmart®



Serviceteile (siehe Seite 38)

XXX = Farbcodierung
 000 = Chrom
 670 = Mattschwarz

Sonderzubehör

(nicht im Lieferumfang enthalten)



- Montageschlüssel #58085000 (siehe Seite 33)



- Installationskit (siehe Seite 34)



- Dichtung #98996000 (siehe Seite 33)



Reinigung (siehe Seite 43)



Bedienung (siehe Seite 36)

- Hansgrohe empfiehlt, morgens oder nach längeren Stagnationszeiten den ersten halben Liter nicht als Trinkwasser zu verwenden.
- Um eine Stagnation in den Anschlussleitungen zu vermeiden, muss nach längeren Gebrauchspausen, mindestens aber jeden dritten Tag, die Armatur in Griffstellung heiß und kalt geöffnet werden bis eine gleichbleibende Auslauftemperatur erreicht ist.



Consignes de sécurité

- ⚠ Lors du montage, porter des gants de protection pour éviter toute blessure par écrasement ou coupure.
- ⚠ Le produit ne doit servir qu'à se laver et à assurer l'hygiène corporelle.
- ⚠ Il est conseillé d'équilibrer les pressions de l'eau chaude et froide.

Instructions pour le montage

- Avant son montage, s'assurer que le produit n'a subi aucun dommage pendant le transport. Après le montage, tout dommage de transport ou de surface ne pourra pas être reconnu.
- Les conduites et la robinetterie doivent être montés, rincés et contrôlés selon les normes en vigueur.
- Les directives d'installation en vigueur dans le pays concerné doivent être respectées.
- La vanne d'écoulement ne doit être utilisée qu'aux fins auxquelles elle a été conçue. La fixation d'autres objets, tels p. ex. qu'une demi-colonne, est interdite sur la vanne d'écoulement.
- En cas de problèmes avec le chauffe-eau, ou bien si le débit d'eau doit être plus important, il est possible d'enlever l'EcoSmart® (limiteur de débit) se trouvant derrière l'aérateur.

Informations techniques

Robinetterie équipée en série d'un EcoSmart® (limiteur de débit)

Pression de service autorisée: max. 1 MPa
 Pression de service conseillée: 0,1 - 0,5 MPa
 Pression maximum de contrôle: 1,6 MPa
 (1 MPa = 10 bar = 147 PSI)

Température d'eau chaude: max. 60°C
 Désinfection thermique: 70°C / 4 min

Le produit est exclusivement conçu pour de l'eau potable!

Description du symbole



Ne pas utiliser de silicone contenant de l'acide acétique!



Etalonnage (voir pages 35)

Réglage de la limitation d'eau chaude. En liaison avec les chauffe-eau, un blocage de l'eau chaude n'est pas recommandable.



Dimensions (voir pages 40)



Diagramme du débit

(voir pages 42)

- ① avec EcoSmart®
- ② sans EcoSmart®



Pièces détachées (voir pages 38)

XXX = Couleurs
 000 = Chromé
 670 = Matt Black

Accessoires en option

(ne fait pas partie de la fourniture)



- clé de montage #58085000 (voir pages 33)



- Mastic d'installation (voir pages 34)



- joint #98996000 (voir pages 33)



Nettoyage (voir pages 43)



Instructions de service

(voir pages 36)

- Hansgrohe recommande de ne pas utiliser le premier demi-litre le matin ou après une période de stagnation prolongée.
- Afin d'éviter une stagnation dans les conduites de raccordement après une inutilisation prolongée, il faut ouvrir au moins une fois tous les 3 jours le robinet en position chaud et froid, jusqu'à l'obtention d'une température de sortie uniforme.



Safety Notes

- △ Gloves should be worn during installation to prevent crushing and cutting injuries.
- △ The product may only be used for bathing, hygienic and body cleaning purposes.
- △ The hot and cold supplies must be of equal pressures.

Installation Instructions

- Prior to installation, inspect the product for transport damages. After it has been installed, no transport or surface damage will be honoured.
- The pipes and the fixture must be installed, flushed and tested as per the applicable standards.
- The plumbing codes applicable in the respective countries must be observed.
- The drain valve must only be used as intended. It is not allowed to attach other objects to the drain valve, for example a semi-pedestal.
- If the instantaneous water heater causes problems or if you wish to increase the water flow, the EcoSmart® (flow limiter) located behind the aerator can be removed.

Technical Data

This mixer series-produced with EcoSmart® (flow limiter)

Operating pressure: max. 1 MPa

Recommended operating pressure: 0,1 - 0,5 MPa

Test pressure: 1,6 MPa

(1 MPa = 10 bar = 147 PSI)

Hot water temperature: max. 60°C

Thermal disinfection: 70°C / 4 min

The product is exclusively designed for drinking water!

Symbol description



Do not use silicone containing acetic acid!



Adjustment (see page 35)

To adjust the hot water limiter. Using a hot water limiter in combination with a continuous flow water heater is not recommended.



Dimensions (see page 40)



Flow diagram (see page 42)

① with EcoSmart®

② without EcoSmart®



Spare parts (see page 38)

XXX = Colors

000 = Chrome Plated

670 = Matt Black

Special accessories (order as an extra)



• special tool #58085000 (see page 33)



• Installation putty (see page 34)



• seal #98996000 (see page 33)



Cleaning (see page 43)



Operation (see page 36)

- Hansgrohe recommends not to use as drinking water the first half liter of water drawn in the morning or after a prolonged period of non-use.
- After periods of prolonged non-use, but at least every third day, the fittings must be opened with the handle in hot and cold position to prevent stagnation in the connecting lines. Let the water run until the water temperature is constant.

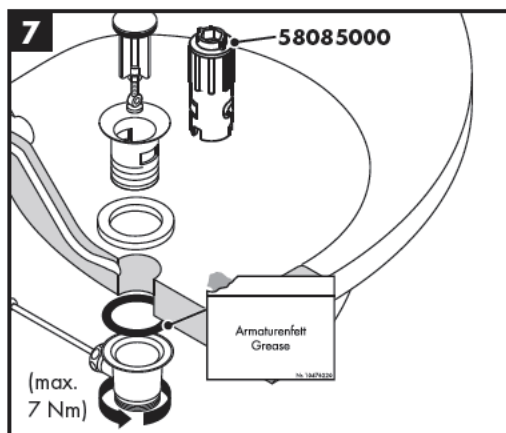
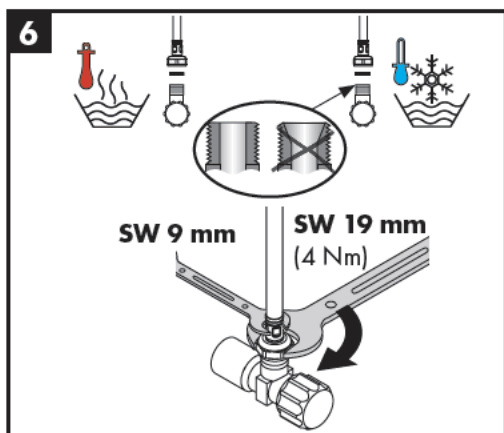
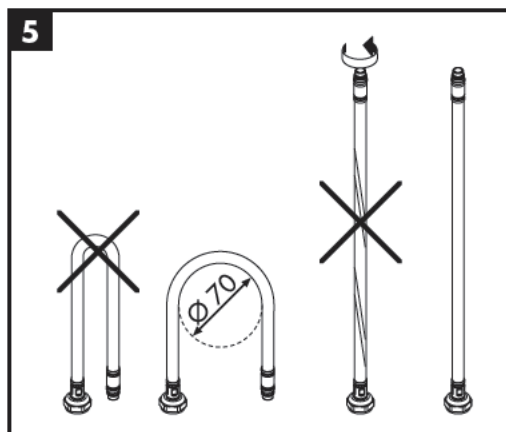
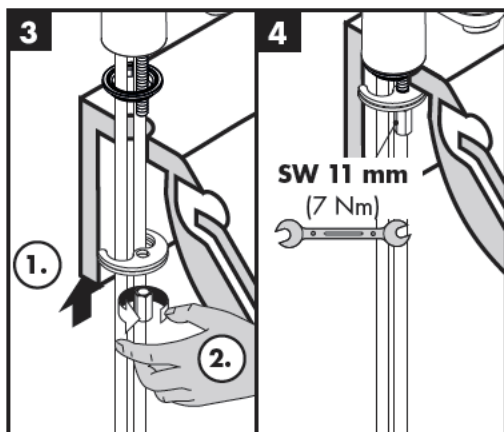
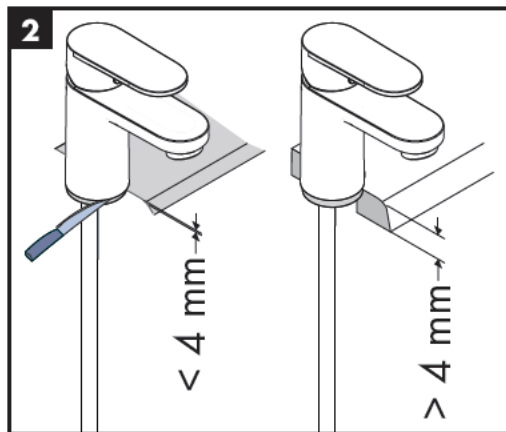
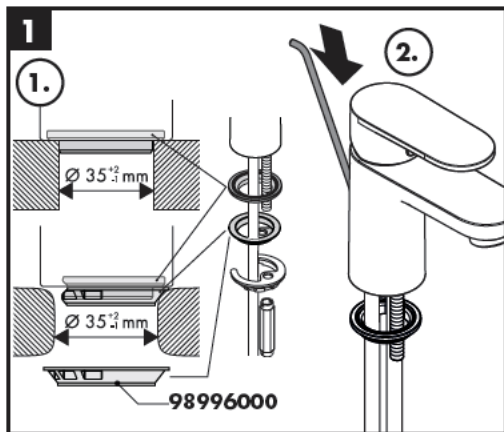

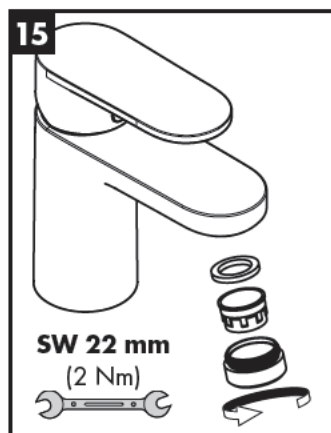
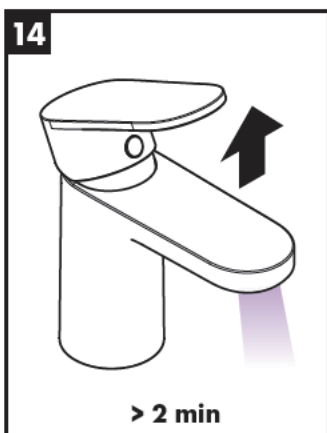
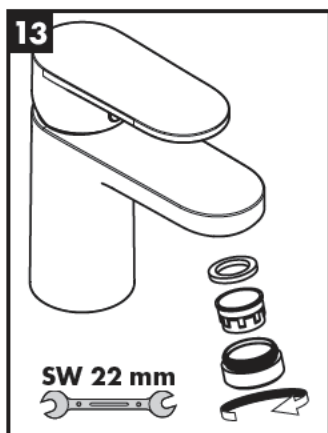
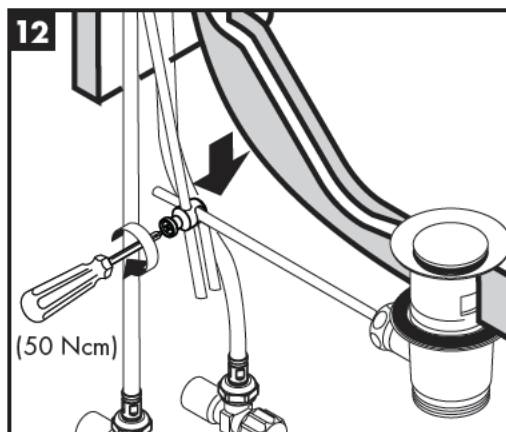
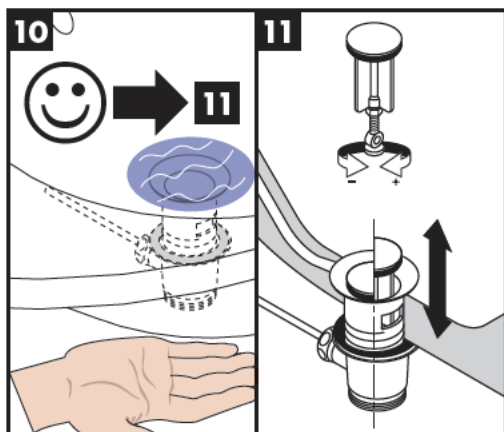
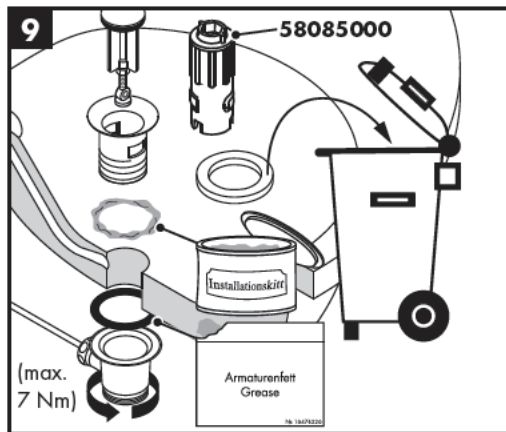
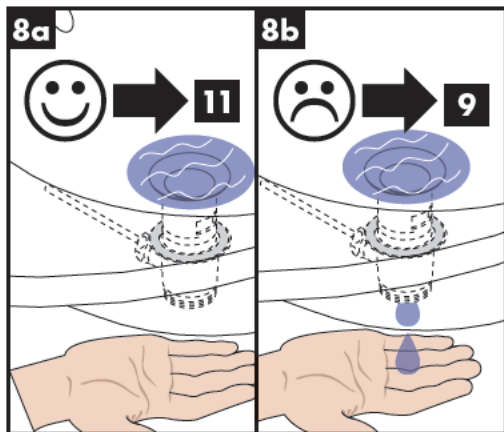

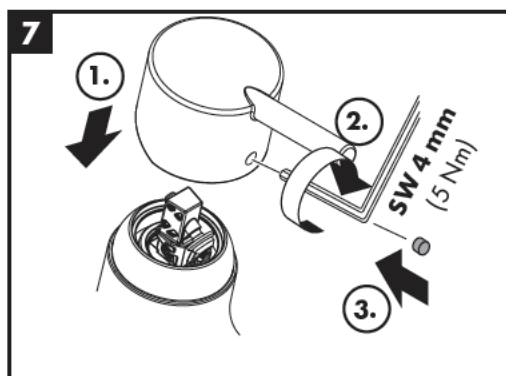
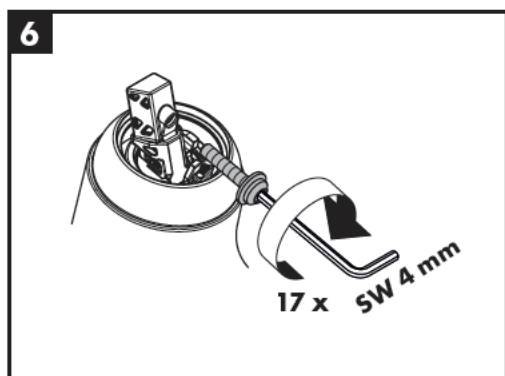
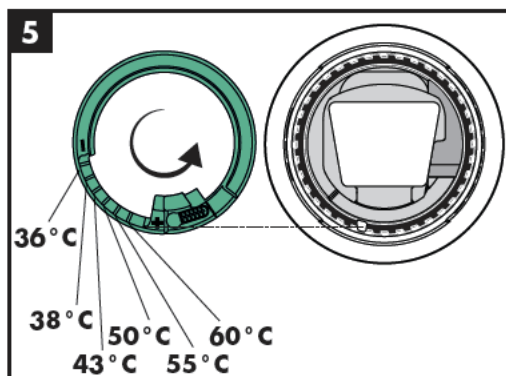
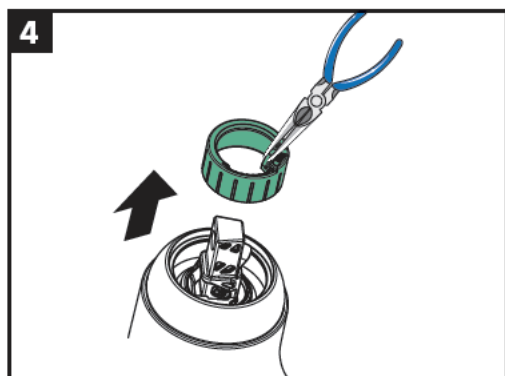
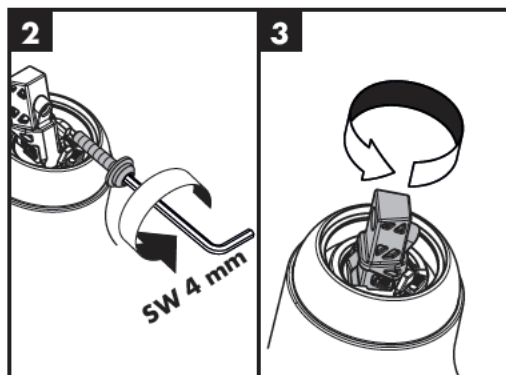
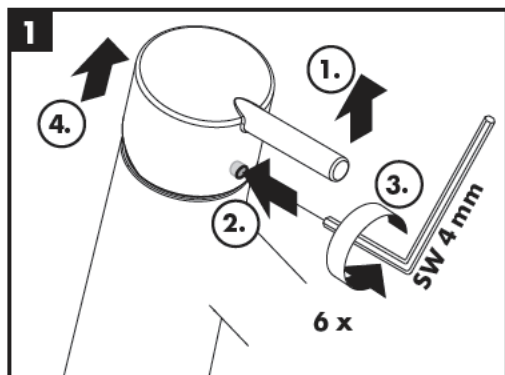



Vernis Blend 70

71550XXX / 71557000 / 71558XXX /
71570000 / 71587000

Vernis Blend 71210XXX

Vernis Blend 100

71551XXX / 71559000 / 71580XXX /
71571000 / 71588000

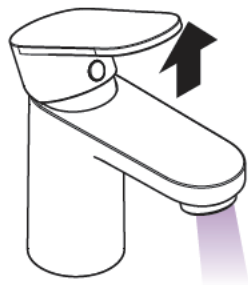

öffnen / ouvert / open

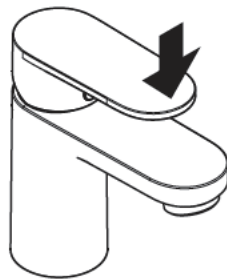

schließen / fermé / close

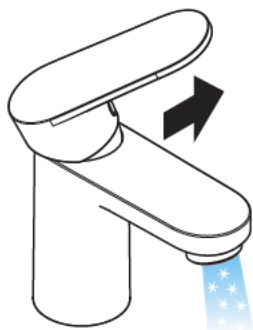

kalt / froid / cold

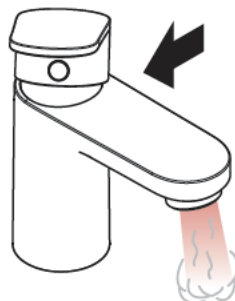

warm / chaud / hot

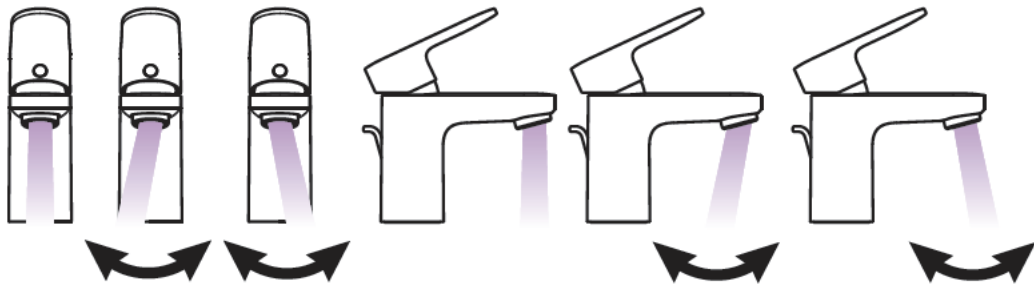



Vernis Blend 70 CoolStart
71584XXX



öffnen / ouvert / open

Vernis Blend 100 CoolStart
71585XXX

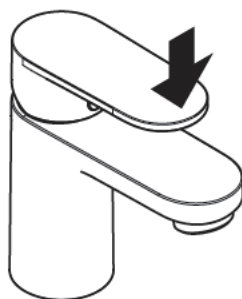

schließen / fermé / close

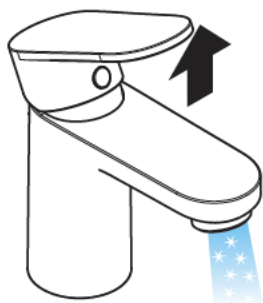

kalt / froid / cold

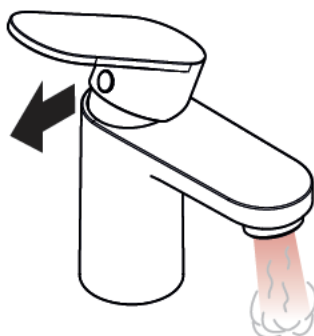

warm / chaud / hot

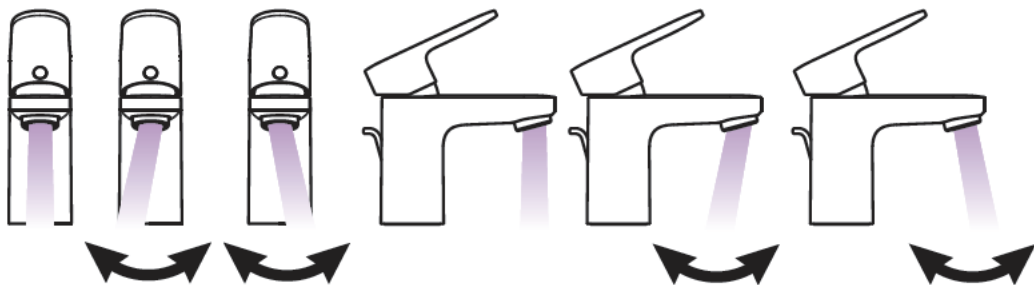



Vernis Blend 70

71550XXX / 71557000 / 71558XXX /
71587000

Vernis Blend 100

71551XXX / 71559000 / 71580XXX /
71588000

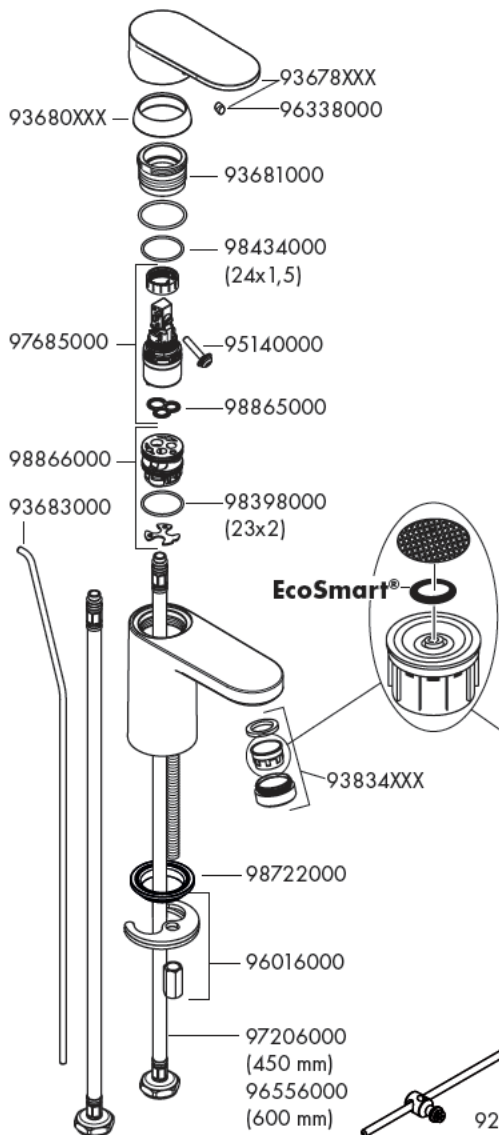

Vernis Blend 70 CoolStart

71584XXX

Vernis Blend 100 CoolStart

71585XXX

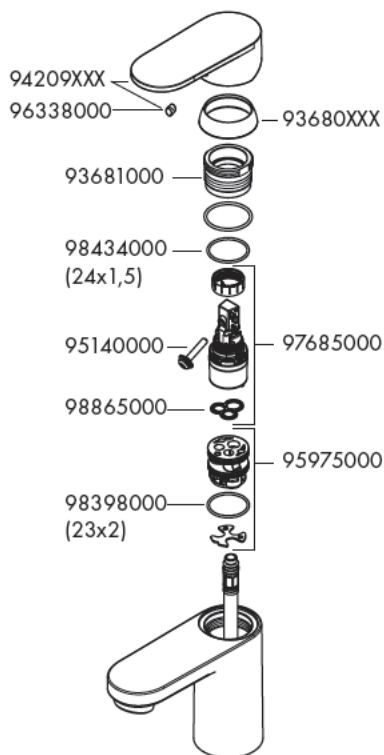

Vernis Blend 71210XXX

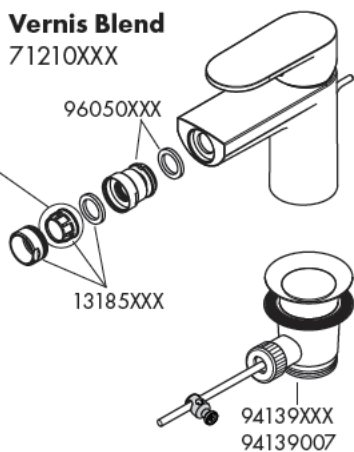



Vernis Blend 70

71570000

Vernis Blend 100

71571000

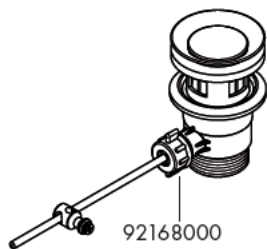
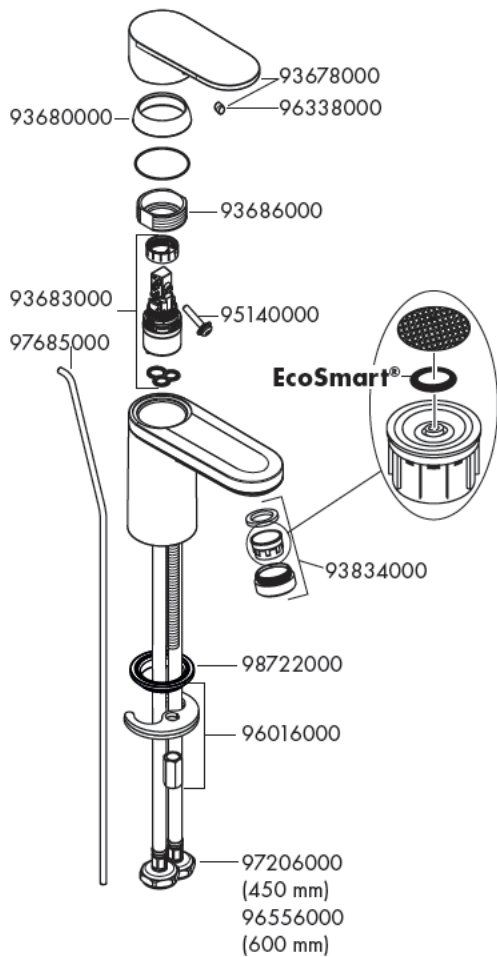



Vernis Blend 70

71550XXX / 71557000 /
71558XXX / 71587000

Vernis Blend 70 CoolStart

71584XXX

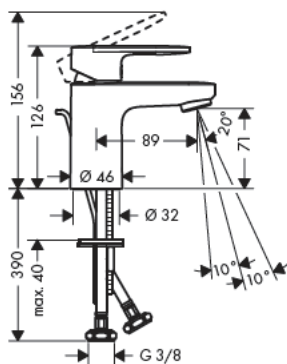

Vernis Blend 100

71551XXX / 71559000 /
71580XXX / 71588000

Vernis Blend 100 CoolStart

71585XXX

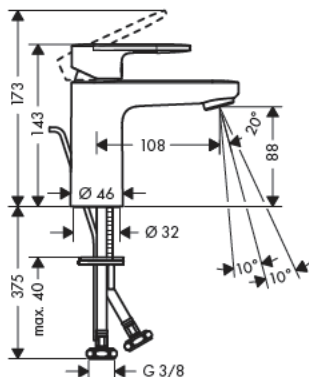

Vernis Blend 70

71570000

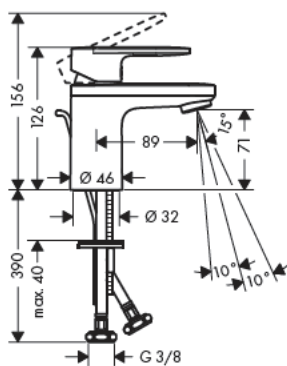

Vernis Blend 100

71571000

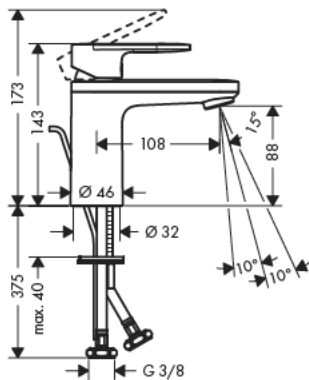

Vernis Blend

71210XXX

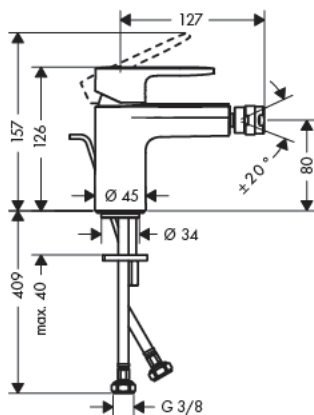

Vernis Blend 70

71550XXX / 71557000 / 71558XXX /
71570000 / 71587000

Vernis Blend 100

71551XXX / 71559000 / 71571000 /
71580XXX / 71588000

Vernis Blend

71210XXX

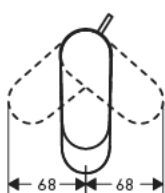

94139007

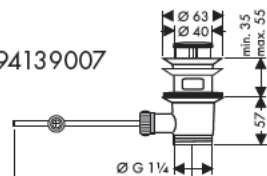

94139000

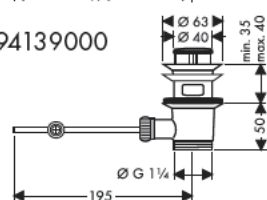

92168000

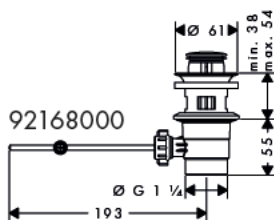

Vernis Blend 70 CoolStart

71584XXX

Vernis Blend 100 CoolStart

71585XXX

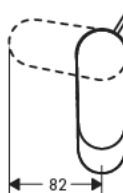



Vernis Blend 70

71550XXX / 71557000 / 71558XXX / 71587000

Vernis Blend 70 CoolStart

71584XXX

Vernis Blend 100

71551XXX / 71559000 / 71580XXX / 71588000

Vernis Blend 100 CoolStart

71585XXX

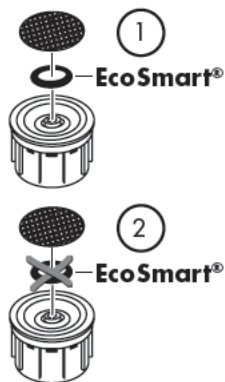
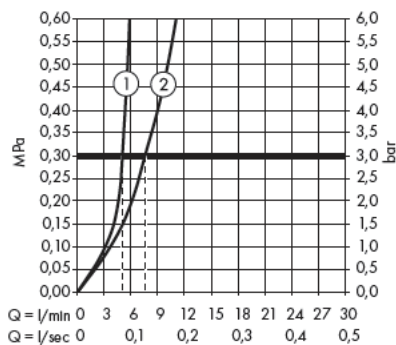

Vernis Blend 70

71570000

Vernis Blend 100

71571000

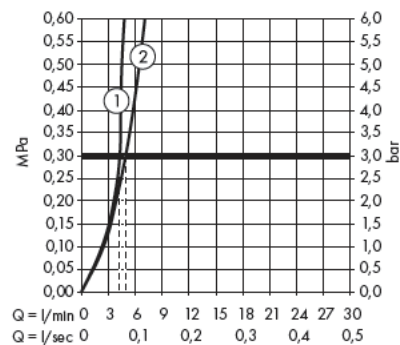

Vernis Blend

71210XXX

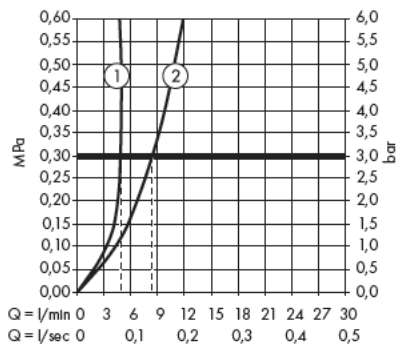



- DE** Reinigungsempfehlung / Garantie / Kontakt
- FR** Recommandation pour le nettoyage / Garanties / Contact
- EN** Cleaning recommendation / Warranty / Contact



[www.hansgrohe.com/
cleaning-recommendation](http://www.hansgrohe.com/cleaning-recommendation)



[www.hansgrohe.com/
cleaning-recommendation](http://www.hansgrohe.com/cleaning-recommendation)



[www.hansgrohe.com/
cleaning-recommendation](http://www.hansgrohe.com/cleaning-recommendation)



[www.hansgrohe.com/
cleaning-recommendation](http://www.hansgrohe.com/cleaning-recommendation)

hansgrohe

Hansgrohe · Auestraße 5 · 9 · D-77761 Schiltach · Telefon +49 (0) 78 36/51-1282 · Telefax +49 (0) 7836/511440
E-Mail: Info@hansgrohe.com · Internet: www.hansgrohe.com

01/2021
9.0713001